LED MOVING WASH



USER MANUAL

FOR YOUR OWN SAFETY, PLEASE READ THIS USER MANUAL CAREFULLY BEFORE POWERING OR INSTALLING YOUR LED MOVING WASH!

Save it for future reference.

This device has left our premises in absolutely perfect condition. In order to maintain this condition and to ensure a safe operation, it is absolutely necessary for the user to follow the safety instructions and warning notes written in this manual.

The manufacturer will not accept liability for any resulting damages caused by the non-observance of this manual or any unauthorized modification to the device.

Please consider that damages caused by manual modifications to the device are not subject to warranty.

The Led Moving Wash was designed for indoor use and it is intended for professional application only. It is not for household use.

1. Safety instructions

DANGEROUS VOLTAGE CONSTITUTING A RISK OF ELECTRIC SHOCK IS PRESENT WITHIN THIS UNIT!

Make sure that the available voltage is not higher than stated on the rear panel of the fixture. This fixture should be operated only from the type of power source indicated on the marking label. If you are not sure of the type of power supplied, consult your authorized distributor or local power company.

Always disconnect the fixture from AC power before cleaning, removing or installing the fuses, or any part.

The power plug has to be accessible after installing the fixture. Do not overload wall outlets and extension cords as this can result in fire or electric shock.

Do not allow anything to rest on the power cord. Do not locate this fixture where the cord may be damaged by persons walking on it.

Make sure that the power cord is never crimped or damaged by sharp edges. Check the fixture and the power cord from time to time.

Refer servicing to qualified service personnel.

This fixture falls under protection class I. Therefore this fixture has to be connected to a mains socket outlet with a protective earthing connection.

Do not connect this fixture to a dimmer pack.

LED light emission. Risk of eye injury. Do not look into the beam at a distance of less than 1 meter from the front surface of the product. Do not view the light output with optical instruments or any device that may concentrate the beam

If the fixture has been exposed to drastic temperature fluctuation (e.g. after transportation), do not switch it on immediately. The arising condensation water might damage your device. Leave the device switched off until it has reached room temperature.

Do not shake the fixture. Avoid brute force when installing or operating the fixture.

This fixture was designed for indoor use only, do not expose this unit to rain or use near water.

When choosing the installation spot, please make sure that the fixture is not exposed to extreme heat, moisture

or dust.

Air vents and slots in the fixture's head and base are provided for ventilation, to ensure reliable operation of the device and to protect it from overheating.

Do not block the LEDs array with any object when the fixture is under operation.

The openings should never be covered with cloth or other materials, and never must be blocked.

This fixture should not be placed in a built-in installation unless proper ventilation is provided.

Only operate the fixture after having checked that the housing is firmly closed and all screws are tightly fastened.

Always use a secondary safety cable when mounting this fixture.

Make sure that the area below the installation place is blocked when rigging, derigging or servicing the fixture.

Do not block the front objective LEDs with any object when the fixture is under operation.

The fixture becomes very hot during operation. Allow the fixture to cool approximately 20 minutes prior to manipulate with it.

Operate the fixture only after having familiarized with its functions. Do not permit operation by persons not qualified for operating the fixture. Most damages are the result of unprofessional operation!

Please use the original packaging if the fixture is to be transported.

Please consider that unauthorized modifications on the fixture are forbidden due to safety reasons!

If this device will be operated in any way different to the one described in this manual, the product may suffer damages and the guarantee becomes void. Furthermore, any other operation may lead to dangers like short-circuit, burns, electric shock, crash etc.

2. Fixture exterior view

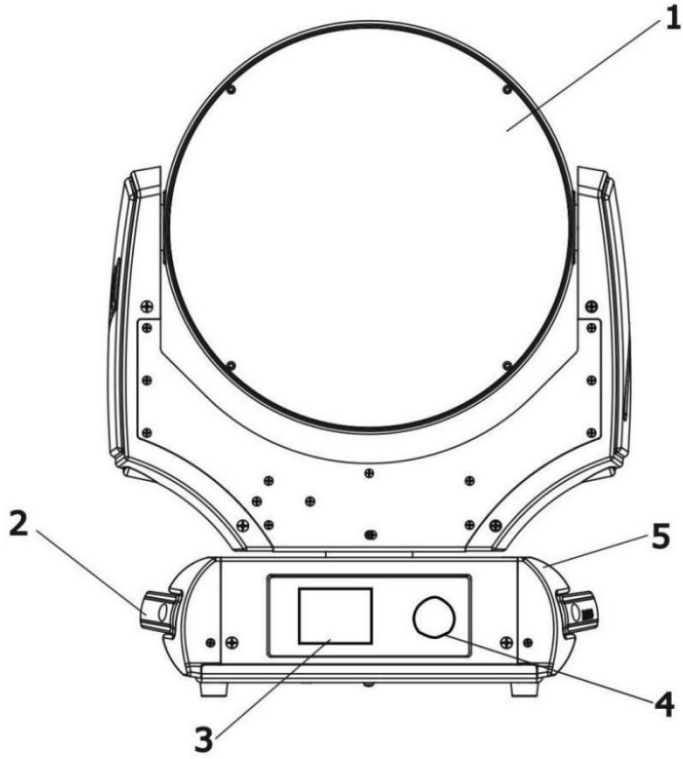

- 1 - Lens array
- 2 - Carrying handle
- 3 - LCD screen
- 4 - Control buttons
- 5 - Base

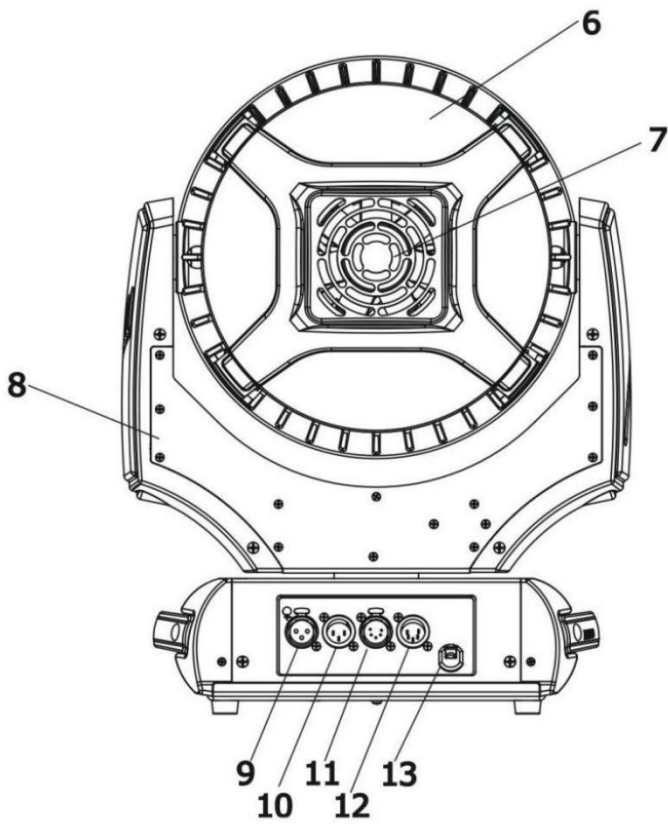

- 6 - Head cover
- 7 - Fan
- 8 - Yoke
- 9 - 3-pin DMX OUT
- 10 - 3-pin DMX IN
- 11 - 5-pin DMX OUT
- 12 - 5-pin DMX IN
- 13 - POWER INw

3. Installation



Fixtures must be installed by a Qualified electrician in accordance with all national and local electrical and construction codes and regulation.

3.1 Connection to the mains

For protection from electric shock, the fixture must be earthed!

The Led Moving Wash is equipped with auto-switching power supply that automatically adjusts to any 50/60Hz AC power source from 100-240 Volts.

Install a suitable plug on the power cord, note that the cores in the power cord are coloured according to the following table. The earth has to be connected!

If you have any doubts about proper installation, consult a qualified electrician.

Core (EU)	Core (US)	Connection	Plug Terminal Marking
Brown	Black	Live	L
Light blue	White	Neutral	N
Yellow/Green	Green	Earth	

3.2 Installing the eggcrate

Switch off the fixture before top hat installation

1. Unscrew the four fastening screws (1) which securing top flange (2) to the head (7) and remove both flange and transparent plastic cover (3) from the head.
2. Unscrew the three fastening screws (4) which securing black eggcrate (5) to the zoom module (6) and remove it.
3. Put the transparent eggcrate on the zoom module (6) and screw it with three screws (4) with washers to the zoom module (6).
4. Place the transparent cover (3) and the top flange (2) back to the head and secure it with four screws (1).

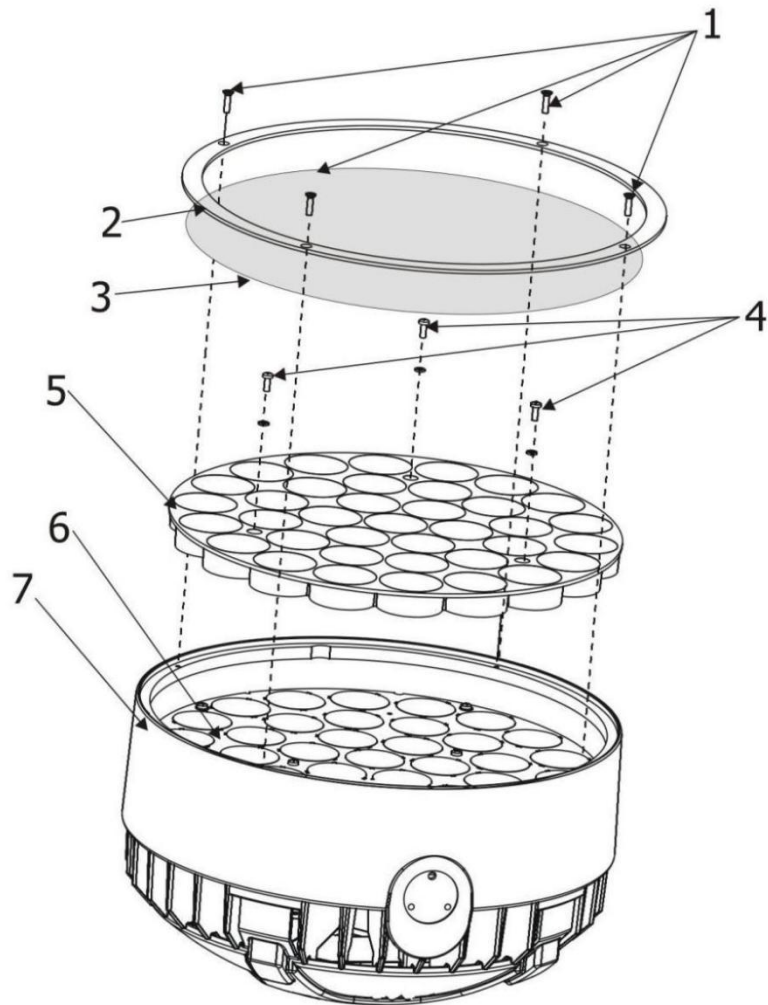

3.3 Rigging the fixture

The installation of the fixture has to be built and constructed in a way that it can hold 10 times the weight for 1 hour without any harming deformation.

The installation must always be secured with a secondary safety attachment, e.g. an appropriate catch net. This secondary safety attachment must be constructed in a way that no part of the installation can fall down if the main attachment fails.

When rigging, derigging or servicing the fixture staying in the area below the installation place, on bridges, under high working places and other endangered areas is forbidden.

The operator has to make sure that safety-relating and machine-technical installations are approved by an expert before taking into operation for the first time and after changes before taking into operation another time.

The operator has to make sure that safety-relating and machine-technical installations are approved by an expert after every four year in the course of an acceptance test.

The operator has to make sure that safety-relating and machine-technical installations are approved by a skilled person once a year.

The fixture should be installed outside areas where persons may walk by or be seated.

IMPORTANT! OVERHEAD RIGGING REQUIRES EXTENSIVE EXPERIENCE, including (but not limited to) calculating working load limits, installation material being used, and periodic safety inspection of all installation material and the projector. If you lack these qualifications, do not attempt the installation yourself, but instead use a professional structural rigger. Improper installation can result in bodily injury or damage to property. The fixture has to be installed out of the reach of people.

If the fixture shall be lowered from the ceiling or high joists, professional trussing systems have to be used. The fixture must never be fixed swinging freely in the room.

Caution: Fixture may cause severe injuries when crashing down! If you have doubts concerning the safety of a possible installation, do not install the moving head!

Before rigging make sure that the installation area can hold a minimum point load of 10 times the fixture's weight.

When installing the device, make sure there is no highly inflammable material (decoration articles, etc.) in a distance of min. 0.5 m.

CAUTION!
Use an appropriate clamp to rig the fixture on the truss.
Follow the instructions mentioned at the bottom of the base.
Make sure that the device is fixed properly! Ensure that the structure (truss) to which you are attaching the fixtures is secure.

The fixture can be placed directly on the stage floor or rigged on a truss without altering its operation characteristics .

For securing a fixture to the truss install a safety wire that can hold at least 10 times the weight of the fixture. Use only safety wire with screw-on carabine. Pull the safety wire through the carrying handles and around the truss as shown on the pictures below.

Note: If the safety wire is too long, whip it several times around the trusses in order to attach the fixture tight. In case of an accident, the way of the falling fixture will be short.

Rigging via two Omega holders

Securing the fixture via one safety wire

Securing the fixture via two safety wires

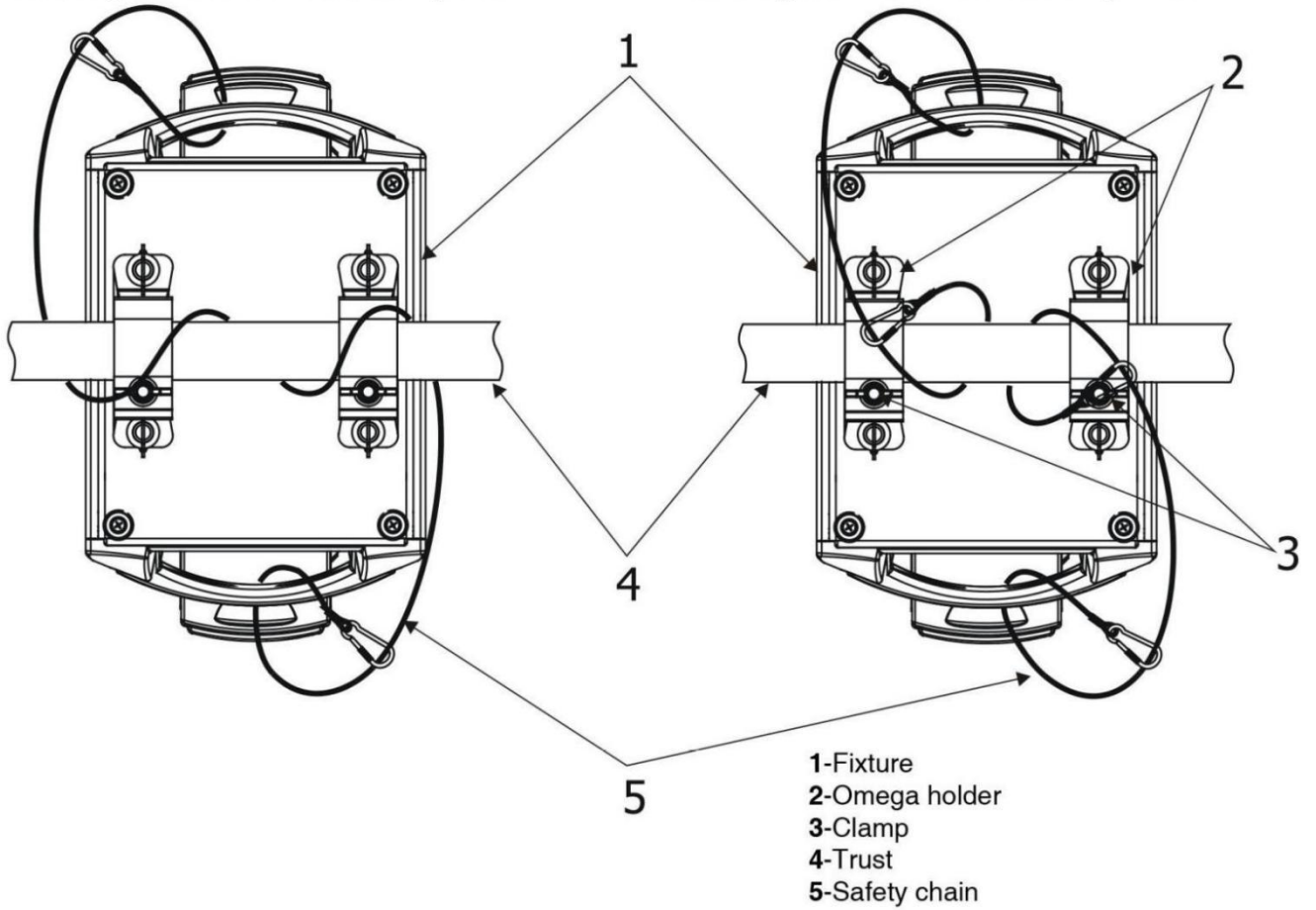

The fixture can be also rigged by means of the mounting adapter (option) for one Omega holder..

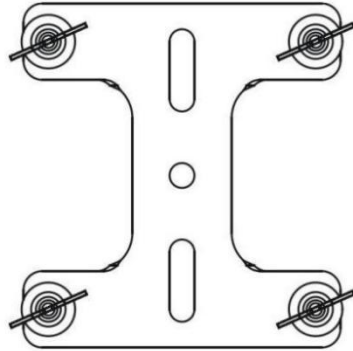

In this case the fixture can hang on the truss in horizontal position only, not sideways .

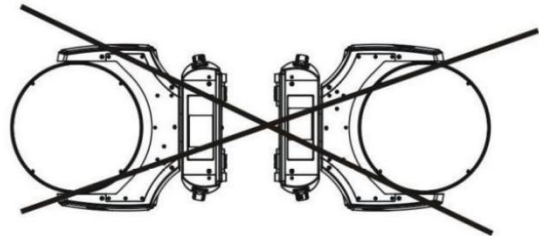
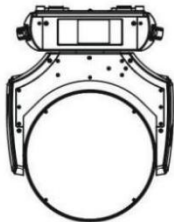

3.4 DMX-512 connection

The fixture is equipped with both 3-pin and 5-pin XLR sockets for DMX input and output. The sockets are wired in parallel.

Only use a shielded twisted-pair cable designed for RS-485 and 3-pin or 5-pin XLR-plugs and connectors in order to connect the controller with the fixture or one fixture with another.

DMX - output

XLR mounting-sockets (rear view):

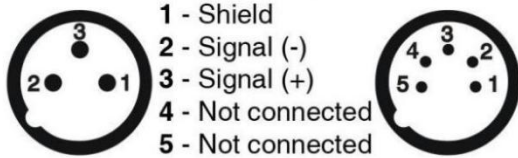

DMX-input

XLR mounting-plugs (rear view):

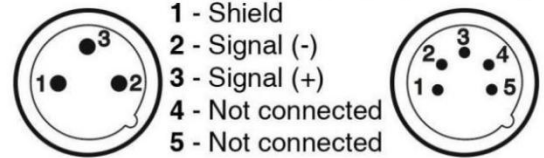

If you are using the standard DMX controllers, you can connect the DMX output of the controller directly with the DMX input of the first fixture in the DMX-chain. If you wish to connect DMX-controllers with other XLR-outputs, you need to use adapter-cables.

Building a serial DMX-chain:

Connect the DMX-output of the first fixture in the DMX-chain with the DMX-input of the next fixture. Always connect one output with the input of the next fixture until all fixtures are connected.

Caution: At the last fixture, the DMX-cable has to be terminated with a terminator. Solder a 120 Ω resistor between Signal (-) and Signal (+) into a 3-pin XLR-plug and plug it in the DMX-output of the last fixture.

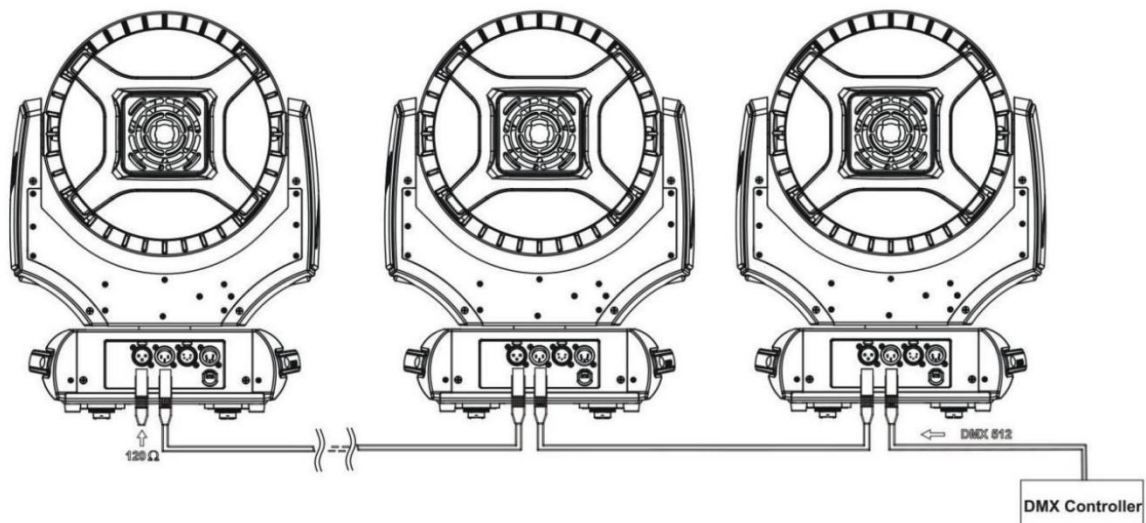

4. LED Moving Wash - DMX chart

Mode/Channel					Value	Function	Type of control
1	2	3	4	5			
1	1	1	1	1	0-255	Pan (8 bit) Pan movement by 450°	proportional
2	2	2	2	2	0-255	Pan Fine (16 bit) Fine control of pan movement	proportional
3	3	3	3	3	0-255	Tilt (8bit) Tilt movement by 300°	proportional
4	4	4	4	4	0-255	Tilt fine (16 bit) Fine control of tilt movement	proportional
5	5	5	5	5	0	Pan/Tilt speed, Pan/Tilt time Max. speed (tracking mode)	step
					1 - 255	<i>P./T. speed-set Speed Mode in menu: P./T. Mode</i> Speed from max. to min. (vector mode)	proportional
					1 - 255	<i>P./T. time - set Time Mode in menu: Pan/Tilt Mode</i> Time from 0.1 s to 25.5 s.	proportional
6	6	6	6	6	0-255	Special functions	proportional
-	7	7	-	-	0-255	Red (8 bit) - all zones Red LEDs saturation control (0-100%)	proportional
-	8	-	-	-	0-255	Red fine(16 bit) - all zones Fine red LEDs saturation control	proportional
-	9	8	-	-	0-255	Green (8 bit) - all zones Green LEDs saturation control (0-100%)	proportional
-	10	-	-	-	0-255	Green fine (16 bit) - all zones Fine green LEDs saturation control	proportional
-	11	9	-	-	0-255	Blue (8 bit) - all zones Blue LEDs saturation control (0-100%)	proportional
-	12	-	-	-	0-255	Blue fine (16 bit) - all zones Fine blue LEDs saturation control	proportional

Mode/Channel					Value	Function	Type of control
1	2	3	4	5			
-	13	10	-	-	0-255	White (8 bit) - all zones White LEDs saturation control (0-100%)	proportional
-	14	-	-	-	0-255	White fine (16 bit) - all zones Fine white LEDs saturation control	proportional
7	-	-	-	14	0-255	Red (8 bit) - zone 1 Red LEDs saturation control (0-100%)	proportional
8	-	-	-	15	0-255	Red fine (16 bit) - zone 1 Fine red LEDs saturation control	proportional
9	-	-	-	16	0-255	Green (8 bit) - zone 1 Green LEDs saturation control (0-100%)	proportional
10	-	-	-	17	0-255	Green fine (16 bit) - zone 1 Fine green LEDs saturation control	proportional
11	-	-	-	18	0-255	Blue (8 bit) zone 1 Blue LEDs saturation control (0-100%)	proportional
12	-	-	-	19	0-255	Blue (16 bit) zone 1 Fine blue LEDs saturation control)	proportional
13	-	-	-	20	0-255	White (8 bit) - zone 1 White LEDs saturation control (0-100%)	proportional
14	-	-	-	21	0-255	White (16 bit) - zone 1 Fine white LEDs saturation control	proportional
15	-	-	-	22	0-255	Red (8bit) - zone 2 Red LEDs saturation control (0-100%)	proportional
16	-	-	-	23	0-255	Red fine (16 bit) - zone 2 Fine red LEDs saturation control	proportional
17	-	-	-	24	0-255	Green (8 bit) - zone 2 Green LEDs saturation control (0-100%)	proportional
18	-	-	-	24	0-255	Green fine (16 bit) - zone 2 Fine green LEDs saturation control	proportional
19	-	-	-	26	0-255	Blue (8 bit) - zone 2 Blue LEDs saturation control (0-100%)	proportional
20	-	-	-	27	0-255	Blue fine (16 bit) - zone 2 Fine blue LEDs saturation control	proportional
21	-	-	-	28	0-255	White (8 bit) - zone 2 White LEDs saturation control (0-100%)	proportional
22	-	-	-	29	0-255	White (16 bit) - zone 2 Fine white LEDs saturation control	proportional
23	-	-	-	30	0-255	Red (8 bit) - zone 3 Red LEDs saturation control (0-100%)	proportional
24	-	-	-	31	0-255	Red fine (16 bit) - zone 3 Fine red LEDs saturation control	proportional
25	-	-	-	32	0-255	Green (8 bit) - zone 3 Green LEDs saturation control (0-100%)	proportional
26	-	-	-	33	0-255	Green fine (16 bit) - zone 3 Fine green LEDs saturation control	proportional
27	-	-	-	34	0-255	Blue (8 bit) zone 3 Blue LEDs saturation control (0-100%)	proportional
28	-	-	-	35	0-255	Blue fine (16 bit) zone 3 Fine blue LEDs saturation control	proportional
29	-	-	-	36	0-255	White (8 bit) zone 3 White LEDs saturation control (0-100%)	proportional
30	-	-	-	37	0-255	White fine (16 bit) zone 3 Fine white LEDs saturation control (proportional

Mode/Channel					Value	Function	Type of control
1	2	3	4	5			
31	15	11	-	12	0 1-255	CTC No function	step
32	16	12	7	13	0 1-2 3 4-5 6 7-9 10-12 13-15 16 17-55 56 57 - 95 96 97 - 134 135 136 - 174 175 176 -214 215 216 - 246 247	Virtual Colour Wheel For detailed description see " Virtual colour wheel- colour mixing chart No function White 2700 K White 2700 K (Halogen lamp mode**) White 3200 K White 3200 K (Halogen lamp mode**) White 4200 K White 5600 K White 8000 K Blue (Blue=full, Red+Green+White=0) Red=0, Green->up,Blue =full, White=0 Light Blue (Red=0, Green=full, Blue =full, White=0) Red=0, Green=full, Blue->down, White=0 Green (Red=0, Green=full, Blue =0, White=0) Red->up, Green=full, Blue=0, White=0 Yellow (Red=full, Green=full, Blue=0, White=0) Red=full, Green->down, Blue=0, White=0 Red(Red=full, Green=0, Blue=0, White=0) Red=full, Green=0, Blue->up, White=0 Magenta (Red=full, Green=0, Blue=full, White=0) Red -> down, Green=0, Blue=full, White=0 Blue (Red=0, Green=0, Blue=full, White=0) ----- <i>Speed of the following effects can be controlled by the Shutter/Strobe channel (DMX values of 96-127)</i> Rainbow effect (with fade time) Rainbow effect Zone effect 1 Zone effect 2 Zone effect 3 Zone effect 4 Zone effect 5 Zone effect 6	step step step step step step step step proportional step proportional step proportional step proportional step proportional step step
33	17	13	8	7	0 - 255	Zoom (8 bit) Zoom from min. to max. beam angle	proportional
34	18	-	-	8	0 - 255	Zoom fine (16 bit) Fine zooming from min. to max.	proportional
35	19	14	9	9	0-31 32-63 64-95 96-111 112-127 128-143 144-159 160-175 176-191 192-223 224-255	Shutter/Strobe Shutter closed Strobe effect from slow--> fast (zone 3 only) Strobe effect from slow--> fast (All zones together) ----- <i>Set value on Virtual colour wheel</i> ----- Zone effects+rainbow effects speed control, slow--> fast Zone effects+rainbow effects speed control, fast--> slow /opposite direction/ Opening pulses in sequences from slow--> fast (All zones together) Closing pulses in sequences from fast--> slow (All zones together) Random strobe effect from slow--> fast (random zone) Random strobe effect from slow--> fast (random zone + random strobe) Random strobe effect from slow --> fast (All zones together) Shutter open	step proportional proportional proportional proportional proportional proportional proportional proportional proportional step

Mode/Channel					Value	Function	Type of control
1	2	3	4	5			
36	20	15	10	10	0-255	Dimmer (8 bit) Dimmer intensity from 0% to 100%	proportional
37	21	-	-	11	0-255	Dimmer fine (16 bit) Fine dimming	proportional

**In the Halogen lamp mode the Dimmer channel imitates behaviour of the halogen lamp during dimming.

5. Technical Specifications

Electrical

Power supply:.....electronic auto-ranging
Input voltage range:..... supply 100-240V, 50/60Hz
Fuse:.....T 4 A@230V
Power consumption:.....430 VA /415W@230V, power factor=0.98

Optic

Light source: 37 RGBW LED multichips
3 zones with individual colour control of each
Typical Lumen Maintenance: 70% @ 60,000 hours
LED life expectancy: 60.000 hours
RGBW colour mixing

Virtual colour wheel

Halogen lamp effect at whites 2700K and 3200K
Rainbow effect with in both directions with variable speed
Zone effects in both directions with variable speed

Strobe

All LED zones together:
Strobe effect with variable speed (0.3 - 20Hz)
Random strobe pulse-effect with variable speed
Opening/closing pulse effect with variable speed
Independent strobe effect with variable speed (0.3 - 20Hz) at LED zone 3
Random strobe and random LED zone effect

Dimmer

Smooth dimmer from 0 - 100 %

Zoom

Motorized

Pan/Tilt

Pan movement range: 450°
Tilt movement range: 300°
16 bit movement resolution
Automatic Pan/Tilt position correction
Remotely controllable speed of pan/tilt movement for easy programming
Movement control: tracking and vector
Pan movement 0° - 450° at max. speed: 2.1 sec. (3.4 sec. - Theatre mode)
Tilt movement 0° - 300° at max. speed:1.1 sec. (2.5 sec. - Theatre mode)

Control

Graphic touch screen for fixture setting and addressing
Gravitation sensor for auto screen positioning
Battery backup of the touch screen
Readout fixture usage, receiving DMX values, temperatures, etc
Built-in analyzer for easy fault finding, error messages
Built-in demo sequences
Theatre mode for silent pan/tilt and zoom moving
Silent fans cooling,
Stand-alone operation

5 DMX modes (37, 21, 15, 10, 37 control channels)

Wireless DMX module (only for Wireless DMX version)

Compliance with USITT DMX-512 and 512-A
Full DMX fidelity and frame integrity
Auto sensing of DMX frame rate and frame size
<5ms DMX latency

Connection

DMX data in/out: Locking 3-pin and 5-pin XLR
AC power input: 1.5 m power cord without plug

Rigging

Mounting points: 2 pairs of 1/4-turn locks
Mounting horizontally or vertically via 2 Omega brackets

Temperatures

Maximum ambient temperature : 45° C
Maximum housing temperature : 75° C

Minimum distances

Min. distance from flammable surfaces: 0.5 m
Min. distance to lighted object: 1.0 m

Total heat dissipation

1330 BTU/h (calculated)

Weight (net):

10.6 kg

Dimensions (mm)

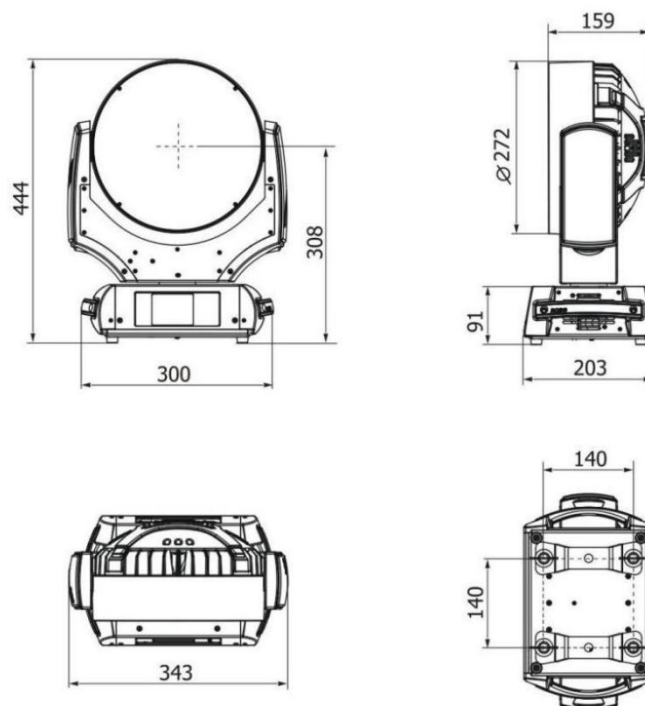

Mounting adapter for one Omega holder

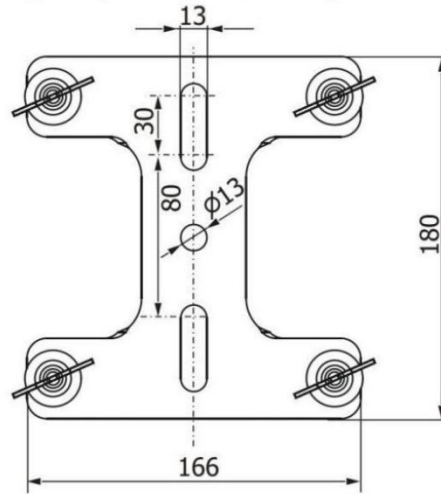

Accessories

Omega holder (No.99010420).....2 pcs

Optional accessories

Top hat-black (No.10980101)

Top hat-white (No.10980103)

Top hat-silver (No.10980111)

Mounting adapter for Omega holder in black (No.10980100)

Mounting adapter for Omega holder in neutral - glazy aluminium (No.10980113)

EggCrate Robin 600 LEDWash-transparent (No. 1098 0114)

11. Maintenance and cleaning

It is absolutely essential that the fixture is kept clean and that dust, dirt and smoke-fluid residues must not build up on or within the fixture. Otherwise, the fixture's light-output will be significantly reduced. Regular cleaning will not only ensure the maximum light-output, but will also allow the fixture to function reliably throughout its life. A soft lint-free cloth moistened with any good glass cleaning fluid is recommended, under no circumstances should alcohol or solvents be used!

DANGER !
**Disconnect from the mains before starting any
maintenance work**

The head's transparent cover will require weekly cleaning as smoke-fluid tends to building up residues, reducing the light-output very quickly. The cooling fans should be cleaned monthly.

The interior of the base should be cleaned at least annually using a vacuum-cleaner or an air-jet.

More complicated maintenance and service operations are only to be carried out by authorized distributors.

11.1 Replacing fuse

Only replace the fuse by a fuse of the same type and rating.

Before replacing the fuse, unplug mains lead!

If you need to replace the main fuse, follow the instructions:

- 1) Remove the rear cover of the base by unscrewing 6 fastening screws.
- 2) Remove the old fuse from the fuseholder.
- 3) Install the new fuse into the fuseholder.

4) Replace the rear cover back to the base..

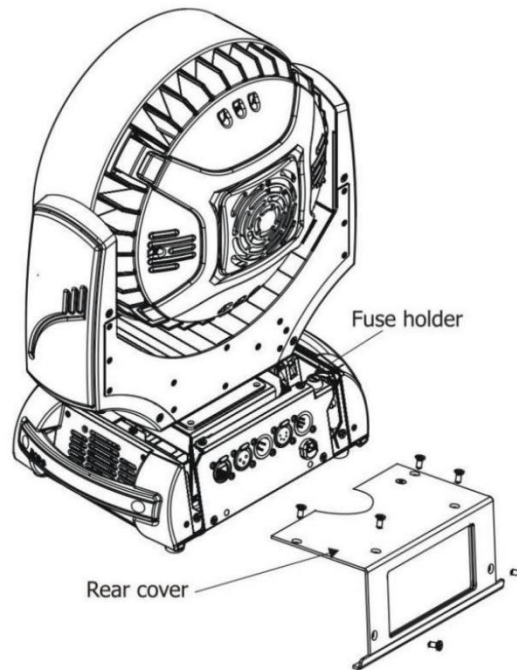

12. ChangeLog

This section summarizes all types of changes in the user manual.

Version of the manual	Date of issue	Description of changes
2.1	14/12/2011	Changes on Power/spec.functions channel, new version of DMX protocol. Menu Personality added items: DMX Input New description of the wireless operation
2.2	2/2/2011	Silent mode of fans added to menu Personality DMX chart v. 1.5: Silent mode of fans added on Power channel (241-255 DMX)
2.3	13/3/2011	LED zone short errors added to error messages

*Specifications are subject to change without notice.
February 26. 2014*

13. Photometric diagrams

Min. zoom

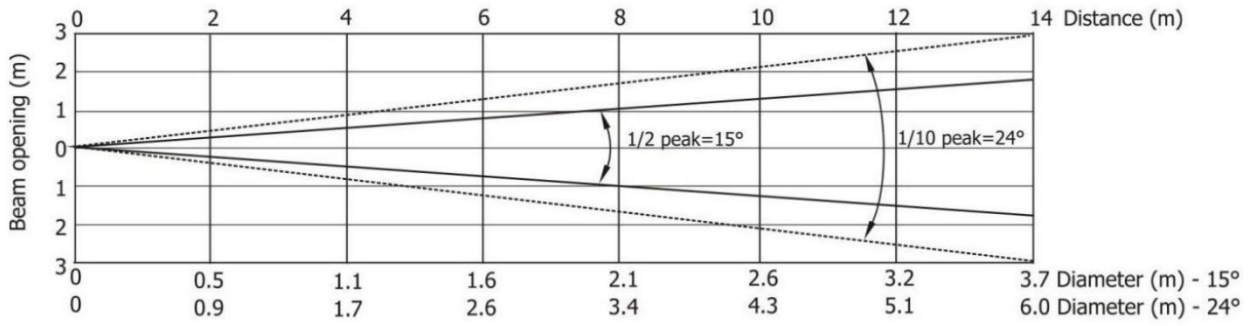

Distance (m)	2	4	5	6	8	10	12	14	
Red	3831/356	958/89	613/57	426/40	240/22	153/14	106/10	78/7	Intensity (center) Lux/Footcandles
Green	6775/629	21694/157	1084/101	753/70	423/40	271/25	188/18	138/13	
Blue	1288/120	322/30	206/19	143/13	81/8	52/5	36/3	26/2.4	
White	9550/887	2387/222	1528/142	1061/99	597/56	382/36	265/25	195/18	
R+G+B+W	20875/1939	5218/485	3340/310	2319/216	1305/121	835/78	580/54	426/40	

Illuminance distribution

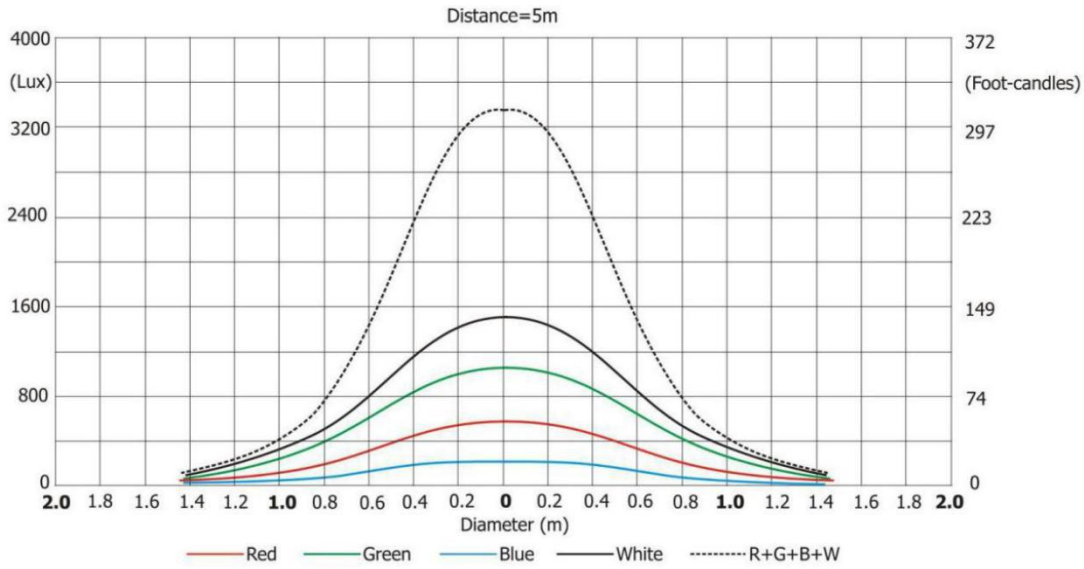

Total output (max.): 4910 lm

Max. zoom

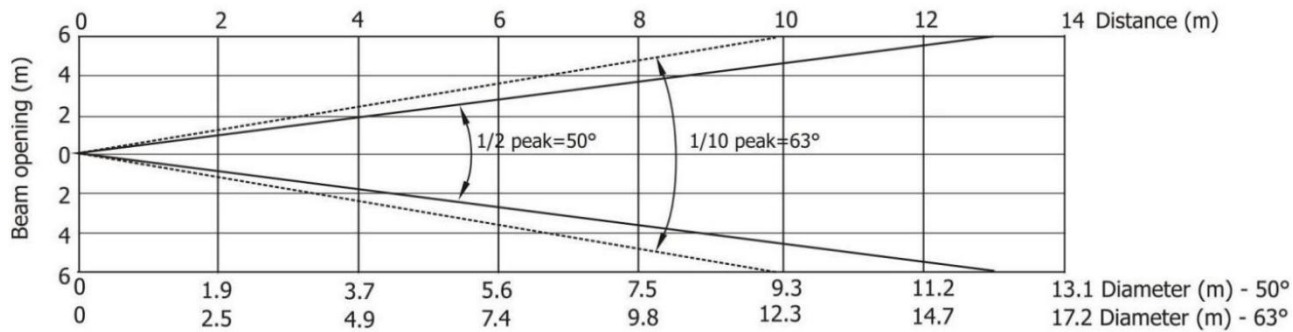

Distance (m)	2	4	5	6	8	10	12	14	
Red	544/51	136/13	87/8	60/6	34/3	22/2	15/1.4	11/1	Intensity (center) Lux/Footcandles
Green	1031/96	258/24	165/15	115/11	65/6	41/4	29/3	21/2	
Blue	200/19	50/5	32/3	22/2	13/1.2	8/0.7	6/0.5	4/0.4	
White	1338/124	334/31	214/20	149/14	84/8	54/5	37/4	27/2.5	
R+G+B+W	3038/282	759/71	486/45	338/31	190/18	122/11	84/8	62/6	

Illuminance distribution

